

Stand-Up™ Lift Parts & Accessories



Frame Jack
BLFJ107



Oil Drain Pan
OD107



18" Service Tool Tray
BLST18



36" Service Tool Tray
BLST36

Visit us at www.KendonUSA.com for product updates, new products, and support.



NO PART OF THIS USER'S GUIDE MAY BE COPIED AND/OR REPRODUCED WITHOUT THE WRITTEN PERMISSION OF KENDON INDUSTRIES, INC. ALL PART NUMBERS, DIMENSIONS AND SPECIFICATIONS IN THIS USER'S GUIDE ARE SUBJECT TO CHANGE WITHOUT PRIOR NOTICE.

COPYRIGHT © 2010 KENDON INDUSTRIES, INC. ALL RIGHTS RESERVED.

Kendon Stand-Up™

TRAILERS & LIFTS

ASSEMBLY AND OPERATIONS MANUAL



KENDON STAND-UP™ BIKE LIFT

KENDON INDUSTRIES, INC.
3707 East La Palma Avenue
Anaheim, CA 92806 USA
Tel 714-630-7144 • Fax 714-630-7132

www.KendonUSA.com

Rev. 071411

NOTES

NOTES**⚠ WARNING**

WARNING: Serious injury, or death, could result through improper use of this product, including crushing or severing type injuries.

WARNING: Bottom scissor may skate across floor when loading depending on the slipperiness of your garage floor. Test grip first and avoid having the lift in front of valuable equipment (i.e. Tool boxes, cars, motorcycles) or people.

WARNING: For Adult Use Only. Keep children away from lift at all times.

WARNING: Bottom scissor safety bar must be engaged at all times to prevent possible lift collapse from hydraulic failure.

WARNING: Lift should only be used on a stable flat surface.

WARNING: Keep hands and feet away from pinch points during raising and lowering of the lift. Keep children away from lift at all times.

WARNING: Do not store or place any objects underneath the lift. Keep the bottom of lift section clear to avoid injury or crushing.

WARNING: Do not exceed lift capacity (Cruiser/Chopper 1000 lbs. Sport/Moto Lift 600 lbs.)

Kendon is not responsible for any consequential damage(s).

Lift Operating Manual

Congratulations on purchasing your new Kendon Lift. Safety is our number one concern. Before using this product, please take the time to read the instructions completely and familiarize yourself thoroughly with the parts on your new Kendon Lift. If you have any questions or need additional instructions, please contact us directly at 714-630-7144 or info@KendonUSA.com.

Visit us at www.KendonUSA.com for product updates, new products, and support.

Getting Started

After 2007, the Kendon Lift is available only as an Air-Over-Hydraulic model. To use your lift with a compressor, simply insert the air fitting on the integrated hose into your compressor. There are many air fittings used by our customers. You may have to switch the fitting to accommodate your compressor. To use your lift with the hand pump, simply use the lift as described elsewhere in the manual.

Before using this product, please take a moment to read the operator's manual completely and familiarize yourself thoroughly with the parts on your new Kendon Stand-Up™ Bike Lift.

Expanded Drawing of Entire Lift ("EDEL" hereafter)

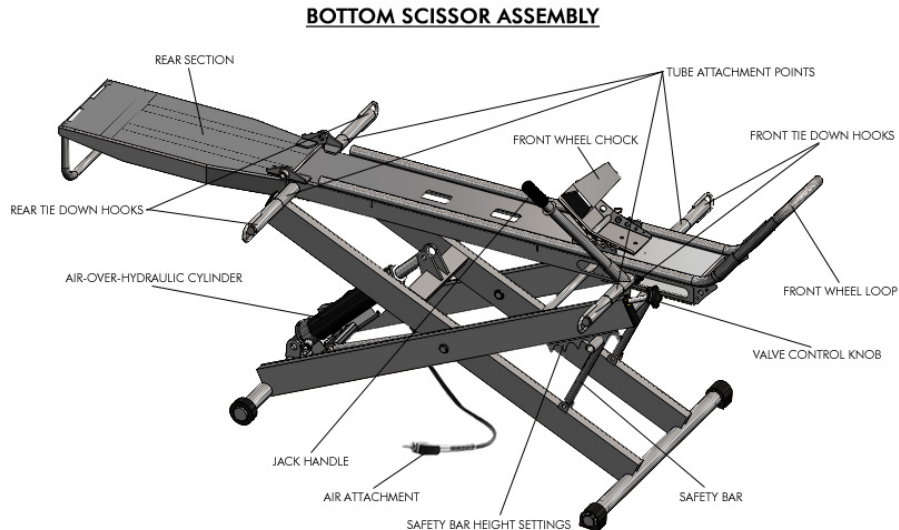

WARNING



WARNING: Serious injury, or death, could result through improper use of this product, including crushing or severing type injuries.

WARNING: Bottom scissor may skate across floor when loading depending on the slipperiness of your garage floor. Test grip first and avoid having the lift in front of valuable equipment (i.e. Tool boxes, cars, motorcycles) or people.

WARNING: For Adult Use Only. Keep children away from lift at all times.

WARNING: Bottom scissor safety bar must be engaged at all times to prevent possible lift collapse from hydraulic failure.

WARNING: Lift should only be used on a stable flat surface.

WARNING: Keep hands and feet away from pinch points during raising and lowering of the lift. Keep children away from lift at all times.

WARNING: Do not store or place any objects underneath the lift. Keep the bottom of lift section clear to avoid injury or crushing.

WARNING: Do not exceed lift capacity (Cruiser/Chopper 1000 lbs. Sport/Moto Lift 600 lbs.)

Kendon is not responsible for any consequential damage(s).

Assembly Instructions

Tools required: Snap ring pliers

Your Lift comes completely assembled, except for the following:

Tie Down Hook Assemblies

Note: The Cruiser and Chopper Lift models do not require front hook assembly as these hooks are welded to the rail assembly.

Attach tie down hooks, front (shorter assembly) with supplied snap rings.

You will find four tie-down hook assemblies in your Lift packaging. Simply slide the shorter tie down hook assemblies onto the round bar connecting the rail to the scissor mechanism. Locate the snap rings on the snap ring groove to retain the tie down hook assemblies in place.

Attach tie down hooks, rear (longer assembly) with supplied snap rings

Repeat process with the rear tie down hook assemblies. These are the longer of tie down hook assemblies.

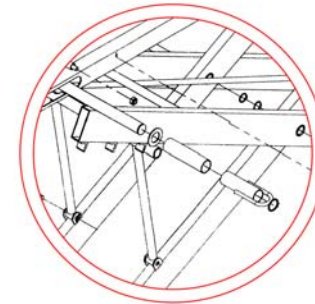

Front Rail Assembly

Attach Front rail hoop with 5/16 diameter quick release pins.

Operating Instructions

Using Your Kendon Stand-Up™ Bike Lift

Before Use

- 1) With ram fully retracted, locate and remove the oil filler plug. Insert the handle into the handle sleeve, and then pump 6 to 8 strokes. This will help release any pressurized air which may be trapped within the reservoir. Ensure the oil level is just below the oil filler plug hole. Reinstall the oil filler plug.
- 2) Check to ensure that the pump operates smoothly before putting into service. Lubricate as instructed in Maintenance Section.
- 3) Inspect before each use. Do not use if bent, broken or cracked components are noted.

Loading

- 1) Lay your Kendon Stand Up™ Bike Lift lying horizontally on the ground. Ensure that it is fully retracted (e.g., ensure that the piston on the jack itself is fully retracted – as with any air-over-hydraulic jack, it can appear to be fully retracted, but can have a small amount of travel remaining). To do this, simply push down on the Rail to confirm that the lift is fully lowered. Fold out the rear section of the Rail Assembly.
- 2) Insert the loading ramp into the rear section of Lift as shown below:

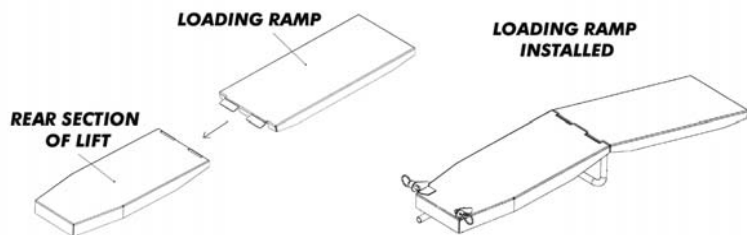

- 3) The ramp is now securely attached and extends out from the back of the folding section of the Lift.
- 4) Ensure the wheel chock on the rail is in the open position. The wheel chock is in the open position when the wheel chock is rotated towards the rear of the rail and the wheel chock channel will receive the front tire of your motorcycle when it is loaded onto the rail.
- 5) **CAUTION:** You must check to ensure that the wheel chock will not contact fender, fairing or other parts of your motorcycle BEFORE loading. The wheel chock is designed to accommodate a variety of motorcycles, but Kendon is not responsible to ensure that the wheel chock will fit any particular motorcycle. Measure clearance BEFORE use.

Warranty Information

Please fill in the required information and return by mail or facsimile to:

Kendon Industries, Inc.
Warranty Department
3707 East La Palma Avenue
Anaheim CA, 92806

(714) 630 7132 Facsimile

Customer: _____

Address: _____

Telephone: _____

E-Mail: _____

Store Where Purchased: _____

Store Address: _____

Date of Purchase: _____

Do you have other Kendon Products? _____

Would Like Information on Other Kendon Products? _____

Warranty

Limited Warranty: Kendon Stand-Up™ Bike Lifts are warranted for a period of 90 (ninety) days from the date of original purchase against defects in material and workmanship. This is a LIMITED WARRANTY and this written warranty is offered in lieu of all other warranties express or implied, except as may be required by law. In order to be eligible for warranty service, the Warranty Registration Card received with your Kendon Stand-Up™ Bike Lift must be completed and submitted to Kendon by the Customer. To request warranty repairs, the Lift must be returned to Kendon by the Customer at the Customer's expense. Customer must also include Original Purchase Receipt. Upon repair, Customer is responsible for the cost to ship the Lift back to Customer. This warranty is not transferable, and may be claimed only by the original purchaser of the Lift. This Limited Warranty becomes null and void in the event that any customer modifications are made to the Lift. This Limited Warranty provides repair or replacement of the Lift only, at Kendon's discretion. This Limited Warranty covers NO consequential or other damages of any kind or nature, or normal wear and tear. In the event of a dispute regarding this Limited Warranty between Kendon and the Customer or any other party, each party shall bear their own legal fees and costs.

Warranty Contact Information:

Warranty Department
Kendon Industries, Inc.
3707 East La Palma Avenue
Anaheim, CA 92806
714-630-7144 Telephone
714-630-7132 Facsimile

- 6) The motorcycle **must** be loaded on the center of the loading ramp. If the motorcycle is off-center, the ramp may be damaged and the motorcycle may fall off the ramp resulting in serious injury or death.

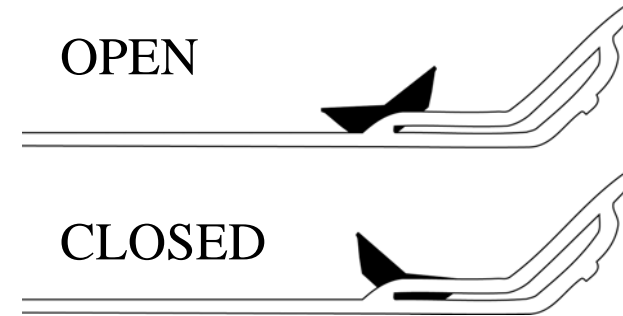

- 7) Standing beside your motorcycle, push it up the ramp and all the way up onto the Rail. As the front wheel on your motorcycle passes over the open wheel chock, the wheel chock will rotate forward. The front tire of your motorcycle will now be pushing down on the wheel chock, which will rotate into the closed position. This causes the wheel chock to clasp the front wheel of your motorcycle in place, holding the motorcycle upright. This is **NOT** a substitute for securely tying your motorcycle onto the Lift using LOCKING RATCHET-STYLE TIE-DOWN STRAPS. Please ensure that the tie-down straps are locked in place and hold the motorcycle safely on the Lift. Failure to correctly and safely tie the motorcycle in place will void your Lift warranty and may cause injury or death in the event that the motorcycle was to become dislodged from the lift.

Correct Tie-Down Procedure - Raising and Lowering your Kendon Stand-Up™ Bike Lift

RAISING THE LIFT

- 1) Your motorcycle is now on the Lift platform and the wheel chock is in the closed position, holding the motorcycle upright. Next, before raising the lift, secure the rear of your motorcycle to the Lift by securing the motorcycle to the **rear** tie-down rings on the Lift. Do not attempt to connect the front of the motorcycle to your Lift until it is raised to the desired working height. Use a connecting point on the REAR of your motorcycle frame such as the frame, swing arm or passenger foot pegs. We recommend using only Kendon locking ratchet tie-down straps. Ratchet the Tie-down straps until motorcycle is secure. This will require you to compress the rear suspension on your motorcycle so there is no possibility that the motorcycle could become dislodged.

- 2) Now you can safely raise the Lift using either a compressor or the hand pump lever.
- 3) Close the Release Valve by turning the Release Valve Assembly to the right one-quarter turn.
- 4) Hydraulic Operation - With Pump Handle securely inserted into the Pump Handle Assembly, actuate the Internal Hydraulic Cylinder by pumping the Pump Handle back and forth. For Air-Over-Hydraulic operation, simply connect your compressor to the Lift and turn on the air. If the lift does not rise, repeat step 3 above, by tightly closing the Release Valve Assembly. Do NOT over-tighten the Release Valve Assembly.
- 5) When the Lift is raised to the desired height, rotate the Locking Safety Bar into place. Make sure the Locking Safety Bar is positioned directly beneath the tabs on the underside of the Lift, because you are about to lower the scissor assembly and lock the Lift in place by dropping it onto the Locking Safety Bar.
- 6) Open the Release Valve Assembly by SLIGHTLY turning it to the left one quarter turn, allowing the Jack to retract (lower) and the Lift to drop onto the Locking Safety Bar.
- 7) If you inadvertently miss the height positioners on the scissor assembly with the Locking Safety Bar, you must quickly close the Release Valve Assembly by turning it to the right again. This will stop the Lift from descending. If that happens, once the Release Valve Assembly is closed once again, use the Pump Handle to raise the Lift and locate the Locking Safety Bar under the teeth on the underside of the Scissor mechanism and repeat step 6.
- 8) Once the Lift is raised to the desired height, rotate the Locking Safety Bar into place and lower the Lift to firmly engage the Locking Safety Bar.
- 9) From the handlebars of the motorcycle (if you have bar-style handlebars) or from some other strong part of the front section of your motorcycle, above the front suspension, secure the motorcycle to the tie down loops on the ends of the Locking Safety Bar. Ratchet the Tie-down straps securely so that the motorcycle suspension is compressed to ensure stability.
- 10) The Lift is now locked in place and secure so that you can work on your motorcycle
- 11) IMPORTANT - Maximum Height – It is possible to raise your Kendon Stand-Up™ Bike Lift above the maximum operating height. This is required so that the Locking Safety Bar can be rotated into place and the Lift lowered upon it. DO NOT raise the Lift any higher than absolutely necessary to clear the Locking Safety Bar. Once the Lift clears the Locking Safety Bar, stop raising the Lift and drop the Lift onto the Locking Safety Bar as described above.

TROUBLESHOOTING

SYMPTOM	POSSIBLE CAUSES	CORRECTIVE ACTION
Jack will not lift load	Release valve not tightly closed Overload condition Hydraulic unit malfunction	Ensure release valve tightly closed Remedy overload condition Ensure adequate air supply
Jack will lift, but not maintain pressure	Release valve not tightly closed Overload condition Hydraulic unit malfunction	Ensure release valve tightly closed Remedy overload condition Contact Kendon for Service
Jack will not lower after unloading	Reservoir overfilled Linkages binding	Drain fluid to proper level Clean and lubricate moving parts
Poor lift performance	Fluid level low Air trapped in system	Ensure proper fluid level With ram fully retracted, remove oil filler plug to let pressurized air escape, then reinstall oil filler plug
Will not lift to full extension	Fluid level low	Ensure proper fluid level

SAFETY PRECAUTIONS

- 1) NEVER ride bike up onto lift.
- 2) DO NOT raise Lift with bike untied.
- 3) Do not hold onto lift while raising and lowering.
- 4) Do not raise or lower lift using your own strength.
- 5) DO NOT put any body parts within the interior frame of the lift while raising or lowering.
- 6) Always use the front swing arm height support.
- 7) Never just use the air jack alone to maintain a raised level height.
- 8) Keep all latches attached in all latching sections.

pressurized air which may be trapped within the reservoir. Ensure the oil level is just below the oil filler plug hole. Reinstall the oil filler plug.

ADDING OIL

- 1) With ram fully lowered and pump piston fully depressed, set jack in its upright, level position. Carefully remove from lift. Remove oil filler plug.
- 2) Fill until oil is level with the filler plug hole. Reinstall oil filler plug.

CHANGING OIL

For best performance and longest life, replace the complete fluid supply at least once per year. Remove the cylinder from the lift and follow this procedure:

- 1) With ram fully lowered and pump piston fully depressed, remove the oil filler plug.
- 2) Lay the jack on its side and drain the fluid into a suitable container.
- 3) Set jack in its level upright position.
- 4) Fill with good quality jack oil. We recommend Mobil DTE 13 or equivalent.

LUBRICATION

- 1) A coating of light lubricating oil to pivot points and hinges will help to prevent rust and assure that pump assemblies move freely.
- 2) Periodically check the pump piston and ram for signs of rust or corrosion. Clean as needed and wipe with an oily cloth.

Using the Lift With the Optional Frame Jack

IMPORTANT – Without the accessory Kendon Frame Jack, the Kendon Stand-Up™ Bike Lift can be used **ONLY** while the **FRONT** and **REAR** of the motorcycle are **BOTH** securely connected to the Lift using Locking Ratchet-style tie-downs. Do **NOT** attempt to raise or lower the motorcycle on the lift **UNLESS** you use the specially designed Kendon Frame Jack. Failure to follow these directions will void the warranty on your Kendon Stand-Up™ Bike Lift and may cause serious injury or death

LOWERING THE LIFT

CAUTION: DO NOT insert any body parts (e.g., fingers, arms, etc.) within the interior frame or scissor assembly of the Lift while raising or lowering your Kendon Stand-Up™ Bike Lift.

- 1) Release the front Tie-down straps from the Locking Safety Bar. Turn the Release Valve Knob one-quarter turn to the right to seal the valve. Raise the Lift slightly (using the hand pump or Air-Over-Hydraulic Cylinder) and rotate the Locking Safety Bar out of the way.
- 2) The Kendon Stand-Up™ Bike Lift is lowered by releasing the Air-Over-Hydraulic Cylinder. **DO NOT OVER-TIGHTEN or OVER-LOOSEN THE RELEASE VALVE** on the Internal Air-Over-Hydraulic Cylinder. One-quarter turn is sufficient to open or seal the cylinder. The Release Valve Knob is the assembly that extends from the bottom of the Air-Over-Hydraulic Cylinder housing to the front of the Lift, located beside the Pump Handle. This Release Valve Assembly should be turned only in small increments. You can control the lowering speed of your Kendon Stand-Up™ Bike Lift by slightly opening and closing the Release Valve Assembly. If you open it up too much, especially with a heavy motorcycle secured to the Lift, the Lift will descend quickly. By “togging” the Release Valve Assembly open and closed during descent, you can safely control the rate of descent as your Kendon Stand-Up™ Bike Lift is lowered to remove the motorcycle from the Lift.
- 3) In the event that you wish to slow or stop the descent of the Lift, simply turn the Release Valve Assembly to the right and the Jack will be sealed and the Lift will stop its descent.
- 4) Insert the ramp into the rear folding section of the Lift.
- 5) When you release the Tie-Down straps the motorcycle will jump or shift somewhat. It is best to have an assistant holding the handlebars of the motorcycle to keep it stable at the moment that the Tie-Down straps are released.
- 6) After releasing the Tie-Down straps, pull the motorcycle out of the wheel chock, and roll the motorcycle off of the Lift. **NOTE** – removing the front wheel of the motorcycle from the Wheel Chock is very easy. However, you may feel more comfortable with this procedure after you have practiced a few times. We **STRONGLY RECOMMEND** that you

have an assistant to help you during the first few times you take the motorcycle out of the Wheel Chock.

Pulling the Motorcycle Wheel out of the Wheel Chock

- 1) With the Tie-Down straps removed, push down on the handlebars of your motorcycle, slightly compressing the front suspension of the motorcycle.
- 2) Pull up and back on the motorcycle handlebars.
- 3) Keeping your hands on the handlebar brake, squeeze the motorcycle brake lever as the Wheel Chock rotates backwards. This freezes the front wheel of the motorcycle at the "balance point" between the closed position and the open position as the Wheel Chock is rotating backwards.
- 4) Pull the motorcycle backwards again, releasing the motorcycle handlebar brake lever. This will cause the Wheel Chock to rotate into the full open position and the front wheel of the motorcycle to fall onto the main Lift rail assembly.
- 5) Now you can roll the motorcycle off of the Lift.

Standing your Kendon Stand-Up™ Bike Lift for Storage

- 1) Fully lower the Bike Lift as described above.
- 2) Remove the Ramp and store it separately.
- 3) Remove all cords, hoses, tie-down straps etc.
- 4) Remove the Pump Handle and store it separately.
- 5) With the Lift now in a horizontal position, fold the folding rear section of Lift closed and attach the rubber latch to the main frame of the Lift.
- 6) In the horizontal position, the Lift stands on four feet. Two have rollers; two do not. The Lift is designed to stand up on the roller feet at the bottom of the scissor assembly.
- 7) Rotate the Kendon Stand-Up™ Bike Lift into a standing position by lifting the non-roller feet (do NOT use the tie-down rings for lifting). Tilt the Lift onto the rollers and continue standing the Lift upright until the support at the bottom of the folded rear section of the Lift touches the floor and Lift is upright standing.
- 8) To move the Lift, tilt it slightly and roll on the rollers to the storage location, then tilt the Lift to a vertical, upright position.
- 9) **IMPORTANT** – the Lift is designed to stand upright. However, it is heavy and may be knocked over. It is IMPERATIVE to secure the upright lift to the wall using a HEAVY DUTY cable. Failure to obey this warning will void the warranty on your Kendon Stand Up Bike Lift and may cause serious injury or death.

Putting the Kendon Stand-Up™ Bike Lift Back Down for Use

When it's time to use your Kendon Stand Up™ Bike lift again, it's important to be careful lowering it from the standing position.

- 1) The Lift weighs over 100 pounds. If you cannot comfortably lift 100 pounds, do NOT attempt to raise or lower the lift to or from the storage position without assistance. Failure to obey this warning will void the warranty on your Kendon Stand-Up™ Bike Lift and may cause serious injury or death.
- 2) With assistance, tilt the Lift down from standing position by securely holding the non-roller feet. Rotate the Lift down until all four feet are securely on the floor. Make sure the Lift is level on a flat concrete or asphalt surface.
- 3) Unlatch rear section and unfold.
- 4) Insert Pump Handle into socket and begin raising lift by cranking the handle back and forth in a semi-circular motion until reaching desired height.
- 5) Unlatch front swing arm height support and align to closest height notch on front legs of lift.
- 6) Release air jack air pressure using the valve at front the front of the lift, using the star shaped knob by turning it to the left, at the same time inserting the front swing arm height support into nearest height notch on front legs of lift.
- 7) Relock air pressure jack with star shaped knob, turning it to the right.

MAINTENANCE

Important: Use only a good grade hydraulic jack oil. Avoid mixing different types of fluid and NEVER use brake fluid, transmission fluid or motor oil. Improper fluid can cause premature failure of the jack and the potential for sudden and immediate loss of load. When used daily with an air compressor, pour a teaspoon of proper lubricant into the air inlet of the lift control valve. Connect valve to air supply and squeeze valve lever to operate. This will evenly distribute lubricant and properly prepare the hydraulic power unit for use. Periodically check for leaks at air connections. Use thread compound to repair. Avoid the use of thread tape when possible.

CYLINDER REPAIR

In case cylinder malfunctions, it may be due to air bubbles in the hydraulic cylinder. In such a case follow this procedure:

With ram fully retracted, locate and remove the oil filler plug. Insert handle into the handle sleeve, then pump 6 to 8 strokes. This will help release any